

Lecture Notes #2: Production

Production: Production Functions

- $Y = F(K, L)$
- Output Y is "cracked" or refined into $C \geq 0$ and $Z \geq 0$ by $C + Z = Y$

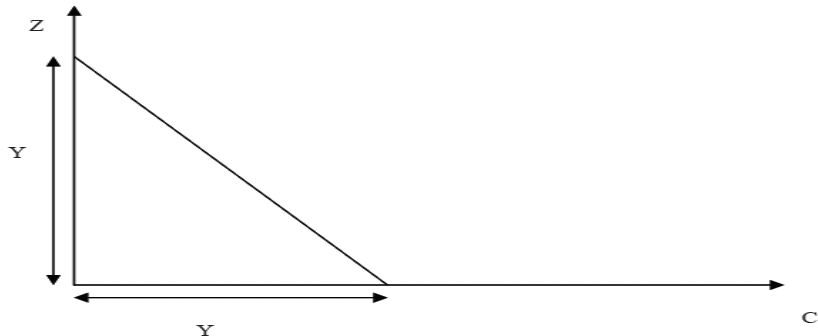

- Slope of PPF = -1, Supply price of new machines in terms of consumption $\frac{P_Z}{P_C} = p_Y = 1$

Production: Production Functions

- Constant-return-to-scale (CRS) means that F is homogeneous of degree one, so that $\theta Y = F(\theta K, \theta L)$ for $(Y, K, L) \geq 0$ and all scalars $\theta > 0$
- Example: log-linear (Cobb-Douglas or Wicksell-Cobb): $Y = AK^aL^b$, where $A > 0$ is a scalar, $0 < a < 1$, $b = 1 - a$
- Let $\theta = 1/L$, then $\frac{Y}{L} = F\left(\frac{K}{L}, 1\right)$ or $y = f(k)$

For Cobb-Douglas: $y = Ak^a$

Production: Production Functions

- Example 2 (Fixed coefficient or Leontief)

$$Y = A \min[aK, bL]$$

Full employment of both factors if and only if $aK = bL$,

$$\frac{Y}{L} = A \min[ak, b] = f(k)$$

Not differentiable, not smooth.

- For the smooth case, we have

$$\text{"Profits"} = F(K, L) - rK - wL$$

$$\frac{\partial Y}{\partial K} = F_K = \frac{\partial F}{\partial K} = r$$

$$\frac{\partial Y}{\partial L} = F_L = \frac{\partial F}{\partial L} = w$$

Production: Production Functions

- $Y = Lf\left(\frac{K}{L}\right)$
 $\frac{\partial Y}{\partial K} = Lf'\left(\frac{K}{L}\right)/L = f'(k) = r$
 $\frac{\partial Y}{\partial L} = f\left(\frac{K}{L}\right) + Lf'\left(\frac{K}{L}\right)\left(-\frac{K}{L^2}\right) = f(k) - kf'(k) = w$
- Checking for adding up:
 $rk + w = kf'(k) + f(k) - kf'(k) = f(k) = y$

- Neoclassical Assumptions:

Positive output: $f(k) > 0$ for $0 < k < \infty$

Positive marginal product: $f'(k) > 0$ for $0 < k < \infty$

Decreasing marginal product: $f''(k) < 0$ for $0 < k < \infty$

- Inada conditions:

$f(0) = 0$, $f(\infty) = \infty$,

$f'(0) = \infty$, $f'(\infty) = 0$

These conditions are used to ensure existence and uniqueness of steady state.

- Show that Cobb- Douglas satisfies the neo-classical conditions and the Inada conditions

Production: Production Function

- Neoclassical technology produces a one-to-one link between capital intensity k and the wage-rental ratio $\omega = \frac{w}{r}$. Hence we can describe the technology by $\omega(k)$ or $k(\omega)$

Proof:

$$\begin{aligned}\omega &= \frac{w}{r} = \frac{f(k) - kf'(k)}{f'(k)} = \frac{f(k)}{f'(k)} - k \\ \frac{d\omega}{dk} &= \frac{f'(k)}{f'(k)} - \frac{f(k)f''(k)}{[f'(k)]^2} - 1 = -\frac{f(k)f''(k)}{[f'(k)]^2} > 0 \\ \frac{dk}{d\omega} &= -\frac{[f'(k)]^2}{f(k)f''(k)} > 0.\end{aligned}$$

graphical proof, next slide:

Production: Production Functions

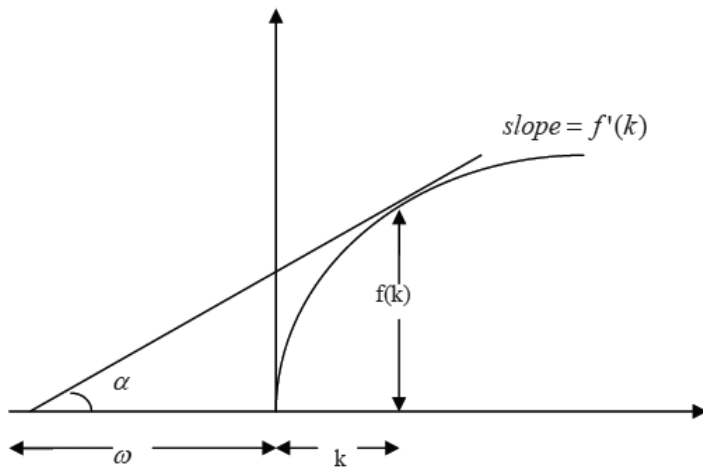

- $\tan \alpha = f'(k) = \frac{f(k)}{k+x}$

solve for x

$$k + x = \frac{f(k)}{f'(k)}$$

$$x = \frac{f(k)}{f'(k)} - k$$

Hence $x = \omega$. Hence $k(\omega)$ and $\omega(k)$ are increasing functions.

- *Problem:*

Do all of the previous exercises for the Cobb-Douglas case:

$Y = AK^aL^{1-a}$. In particular, derive $k(\omega)$ and $\omega(k)$ for this case.

Production: Production Functions

- Leontief case. Caution: Use calculus at your own risk. (generalized sub-gradients).

$$y = \min(ak, b) = f(k)$$

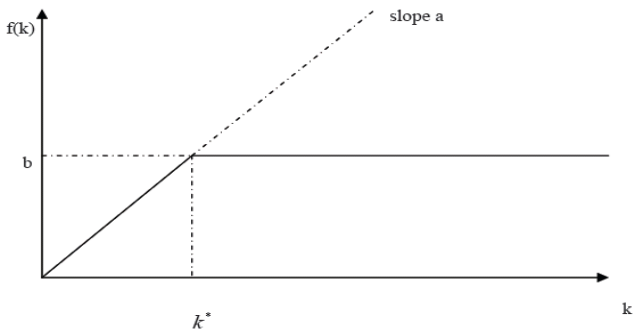

For $0 < k < k^*$, $r = a$, $w = 0$

For $k^* < k$, $r = 0$, $w = b$

For $k^* = k$, $rk + w = ak = b$. $r \leq a$. $w \leq b$.

Production: Production Functions

- CES Production

Reference: Arrow, Chenery, Minhas, & Solow The Review of Economics and Statistics, Vol. 43, No. 3 (Aug., 1961), pp. 225-250

$$\sigma = \frac{Ek}{E\omega} = \frac{\frac{dk}{d\omega}}{\frac{k}{\omega}} = \frac{-f'(f - kf')}{kff''} > 0$$

- Cobb-Douglas case

$$f = Ak^a$$

$$f' = Aak^{a-1}$$

$$f'' = Aa(a-1)k^{a-2}$$

$$\sigma = \frac{Ek}{E\omega} = \frac{\frac{dk}{d\omega}}{\frac{k}{\omega}} = \frac{-f'(f - kf')}{kff''} = \frac{-Aak^{a-1}(Ak^a - kAak^{a-1})}{kAa(a-1)k^{a-2}} = 1$$

$\sigma = 1$ for Cobb-Douglas case.

Production: Production Functions

- Leontief (Perfect Complements)

$$\sigma = 0$$

- Data:

$$0 \ll \sigma \ll 1$$

- CES PF:

$$Y = (AK^{-\rho} + BL^{-\rho})^{-1/\rho}$$

$$y = (Ak^{-\rho} + B)^{-1/\rho}$$

$$\sigma = \frac{1}{1+\rho}$$

- Show CES is neoclassical for $y, A,$ and B greater than zero and ρ greater than minus one, but the Inada Condition will not hold
- Perfect Substitutes, say $Y = (aK + bL)$

$$\sigma = \infty.$$

2-sector production:

- *Reference:* H.Uzawa, "On a Two-Sector Model of Economic Growth II," *Review of Economic Studies*, Vol June 1963, 30(2): 105-118.
- For 2, think C. For 1, think I or Z. $p = \frac{P_Z}{P_C}$
 - $Y_j = F_j(K_j, L_j) \quad j = 1, 2$
 - (FE) $K_1 + K_2 = K, \quad L_1 + L_2 = L$
 - $Y = Y_2 + pY_1$
 - $k = \frac{K}{L}, \quad y = \frac{Y}{L},$
 - $k_j = \frac{K_j}{L_j}, \quad y_j = \frac{Y_j}{L_j},$
 - $l_j = \frac{L_j}{L}$

2-sector production:

Hence

- $y_j = l_j f_j(k_j) \quad j = 1, 2$
- (FE) $k_1 l_1 + k_2 l_2 = k, \quad l_1 + l_2 = 1, \quad l_2 = 1 - l_1$
- $p = \frac{f_2'(k_2)}{f_1'(k_1)}$
- $\omega = \frac{f_j(k_j)}{f_j'(k_j)} - k_j > 0$
- $y_1 = l_1 f_1(k_1) = \left(\frac{k_2 - k}{k_2 - k_1}\right) f_1(k_1)$
- $y_2 = l_2 f_2(k_2) = \left(\frac{k - k_1}{k_2 - k_1}\right) f_2(k_2)$
- l_1 and l_2 are positive because k is a convex combination of k_1 and k_2
- $\frac{dk_j}{d\omega} = \frac{-[f_j']^2}{f_j f_j''} > 0$

$k_j(\omega)$ for $j = 1, 2$ describes the technology.

Exercise: Show the expressions for $k_j(\omega)$ if the 2 PF's are Cobb-Douglas.

2-sector production:

- Log differentiating p w.r.t ω yields

- $\log(p) = \log(f_2'(k_2(\omega))) - \log(f_1'(k_1(\omega)))$

- $\frac{1}{p} \frac{dp}{d\omega} = \frac{f_2'' \frac{dk_2}{d\omega}}{f_2'} - \frac{f_1'' \frac{dk_1}{d\omega}}{f_1'} = \frac{1}{k_1(\omega) + \omega} - \frac{1}{k_2(\omega) + \omega}$

- $\frac{dP}{d\omega} > 0$ if $k_2(\omega) > k_1(\omega)$
 $\frac{dP}{d\omega} = 0$ if $k_2(\omega) = k_1(\omega)$
 $\frac{dP}{d\omega} < 0$ if $k_2(\omega) < k_1(\omega)$

- $k_2(\omega) > k_1(\omega)$ thought to be "usual"

2-sector production: Harrod-Johnson diagram

usual case $k_2(\omega) > k_1(\omega)$

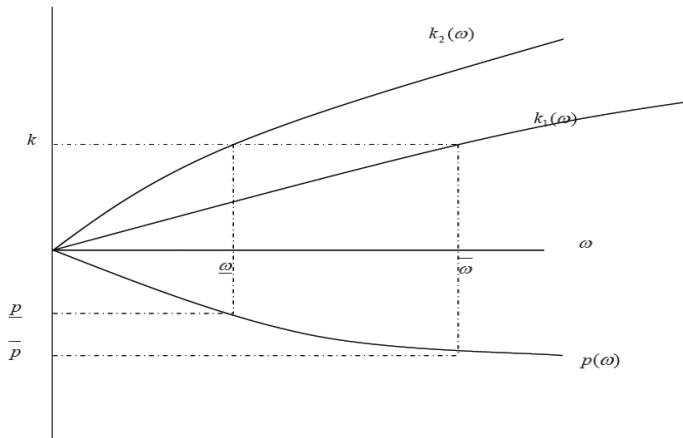

2-sector production: Harrod-Johnson diagram

case $k_1(\omega) > k_2(\omega)$

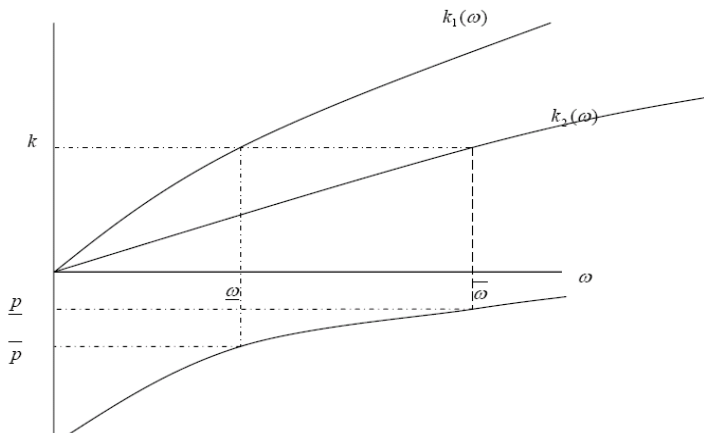

2-sector production: Harrod-Johnson diagram

case $k_1(\omega) = k_2(\omega)$

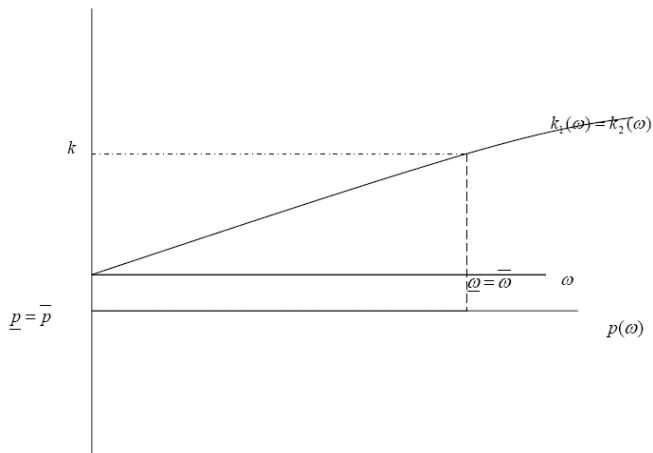

Like 1-sector !

2-sector production: Harrod-Johnson diagram

Crossing factor intensities:

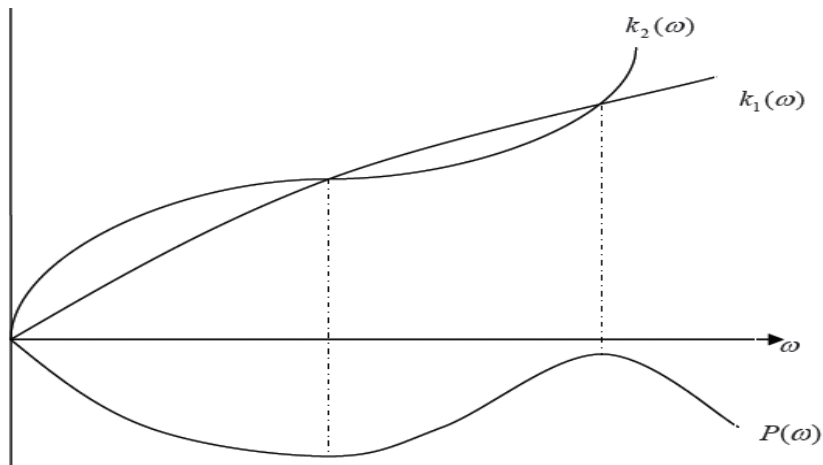

No factor-price equalization

2-sector production

- Factor price equalization holds if capital intensity schedules do not cross.
- When factor price equalization holds (assuming non-specialization), then free, costless trade in outputs makes trade in factors "redundant".

2-sector production

case 1: $k_1(\omega) \neq k_2(\omega)$

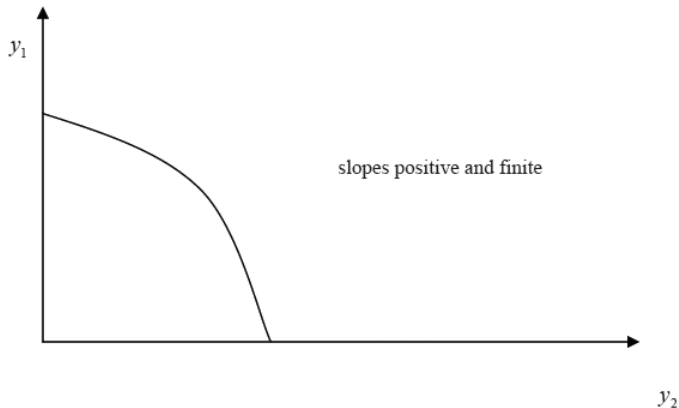

2-sector production

case 1: $.k_1(\omega) = k_2(\omega)$

